

SJT-ZPC-V2A(VM1) Safety Board

(Advance Open door & Re-leveling Safety Circuit and
Unintended Car Movement detection device)

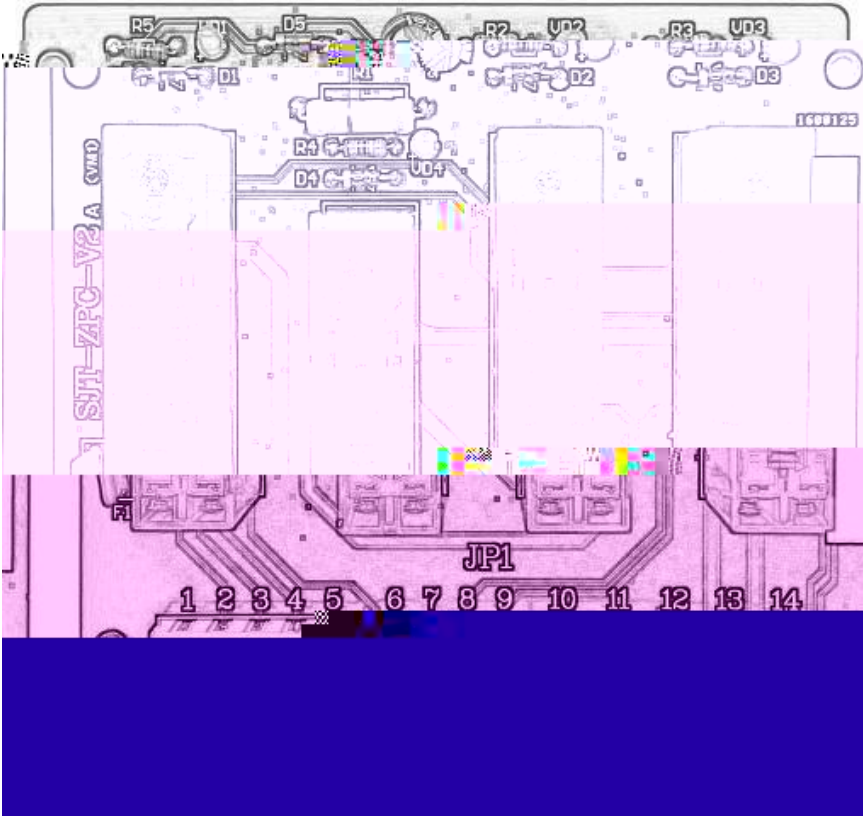

Content

| | |
|--|---|
| Content..... | 1 |
| 1 Foreword | 2 |
| 2 Attention..... | 2 |
| 3 Usage..... | 3 |
| 3.1 Configuration | 3 |
| 3.2 System Application Composition | 3 |

3 Usage

3.1 Configuration

Chart 1 Product configuration of detection Subsystem

| | | | |
|---|--|---|---|
| Subsystem Model | SJT-ZPC-V2A(VM1) | | |
| Hardware Version | V2A(VM1) | Software Version | None |
| Hardware Components | PCB & Safety relay & Capacitance & Resistance & Diode & LED & Terminal | | |
| Installation position of sensor | On car top and between level switch | Max vertical distance corresponding to elevator level base plane in detection range of re-leveling sensor | Less than 160mm |
| Suitable explosion-proof form | Not suitable Install in explosion-proof cabinet while using for explosion-proof elevator | Response time of Subsystem | 15ms |
| Suitable subsystem form for trigger and brake | Released status when power on and active status when power off | Test speed | Less than 0.3m/s |
| Suitable environment | Indoor | Working condition | Temperature: -20 ~ +65 ; Humidity: RH, no water drop |

3.2 System Application Composition

Re-leveling and Advance door open function is composed by power & SJT-ZPC-V2A(VM1) (short for re-level board) & sensor & elevator control board. It need external switch power to supply DC 24V for re-leveling board. Up & Down re-leveling sensors installed in the middle of up & down door zone sensor connect to re-level board, detect safety unlocking zone and supply safety unlocking zone signals to elevator control board. Shorting door circuit is under main board control. When main board find safety unlocking zone signals and suitable condition for re-leveling and advance open door, it will output control signal and door circuit will be shorted by safety board. Then elevator operates re-leveling or advance open door according to detected signals and running condition.

For unintended car movement protection (UCMP) application, SJT-ZPC-V2A(VM1)

safety board is a subsystem of UCMP device, which is UCMP detection subsystem. SJT-ZPC-V2A(VM1) can cooperate with main brake of traction machine & additional brake & electric rope gripper & rail clamping & electric overspeed governor & safety gear & mechanical rope gripper and other trigger and brake subsystem. It require trigger and

3.4 Terminal and Connection

Chart 2 Terminal Definition

| Port | Position | Definition | Type | Rated capacity |
|------|----------|-------------------------------------|----------------|---------------------------|
| JP1 | JP1-1 | DC24V+ | Power | 400mA |
| | JP1-2 | 0V | | |
| | JP1-3 | Up re-leveling door zone | Input | DC24V, 40mA |
| | JP1-4 | Down re-leveling door zone | Input | DC24V, 40mA |
| | JP1-5 | Re-leveling door short input | Input | DC24V, 40mA |
| | JP1-6 | Re-leveling condition output | Contact output | DC24V, <5A |
| | JP1-7 | Re-leveling condition output common | | |
| | JP1-8 | Re-leveling door zone output | Contact output | DC24V, <5A |
| | JP1-9 | Re-leveling door zone output common | | |
| | JP1-10 | Door short and UCMP output 1 | Contact output | AC110V, <5A |
| | JP1-11 | Door short and UCMP output 1 | | |
| | JP1-12 | UCMP output 2 | Contact output | AC250V, <5A DC24V, <5A |
| | JP1-13 | UCMP output 2 | | |
| | JP1-14 | Rear door short detection | Contact output | AC110V, <5A |

3.5 Circuit Schematic Diagram

In figure 3, it describes connection between SJT-ZPC-V2A(VM1) and main board (MU_V61 series).

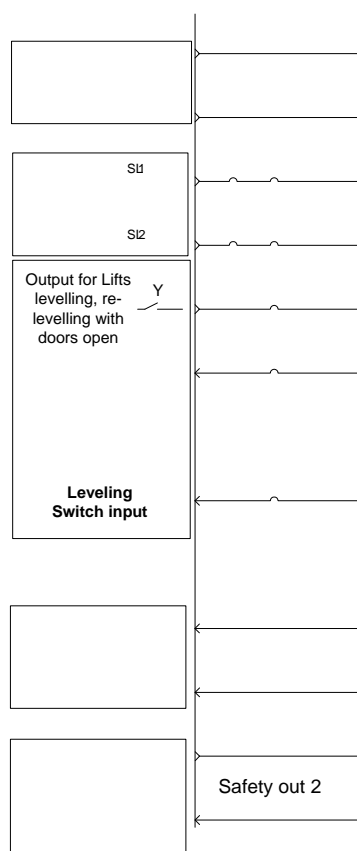

Figure 3 System composition diagram

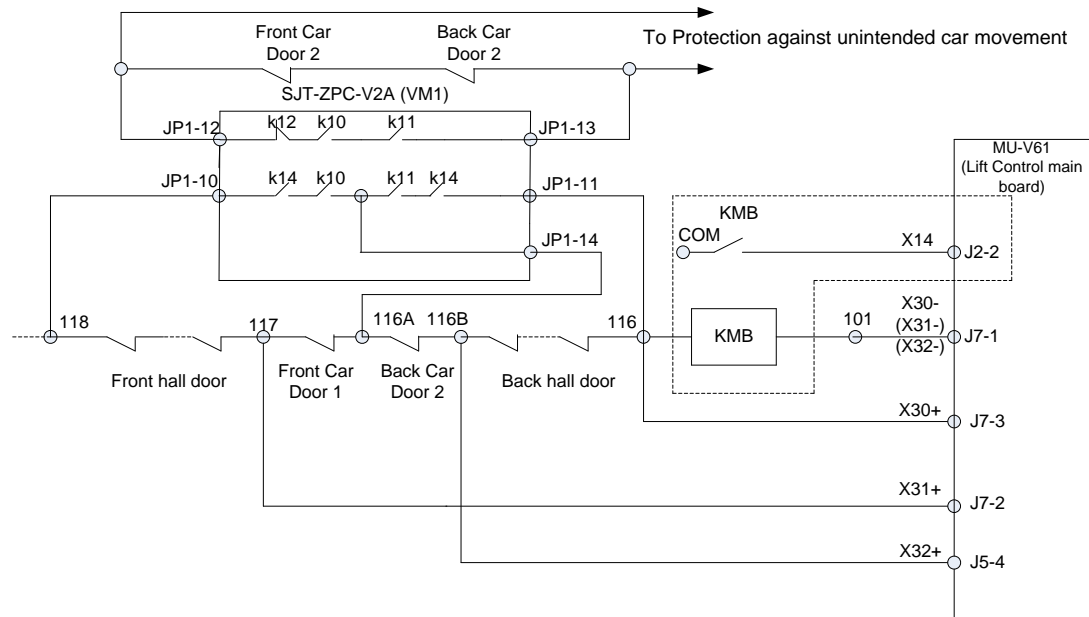

Figure 6 Advance door open & re-leveling & UCMP test & Door short detection control when two door (suit for geared machine)

3.6 Installation of Sensor

When using re-leveling or advance open door function, two re-leveling door zone sensors need to be installed. mq1: up door zone; mq2: down door zone; sl1: up re-leveling door zone, sl2: down re-leveling door zone (require magnetic sensor); each door zone sensor should be installed in sequence, otherwise re-leveling may run to opposite direction.

Note:

1. Installation distance requirement of S1. The distance of S1 should be more than 45mm and less than 160mm. If distance of S1 is over 160mm, it will affect brake distance of UCMP.
2. The distance of S2 should be more than 25mm to prevent SL1 and SL2 from false action by mutual inductance.

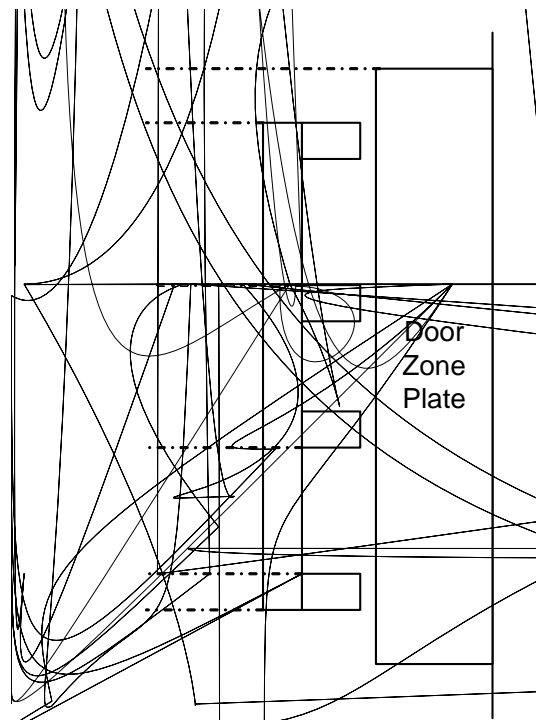

Figure 7 Installation of door zone sensor

3.7 Function description

3.7.1 Advance open door

While elevator arrives at destination floor and decelerates to the speed below International standard EN81 regulation, re-leveling board detect up and down re-leveling door zone signals and cooperate with elevator control board to short door circuit. Then operate open door within safety unlocking zone while low speed running. After stop brake of traction machine has turned off, so it will release door circuit short after car keep static. Time sequence is shown as follow:

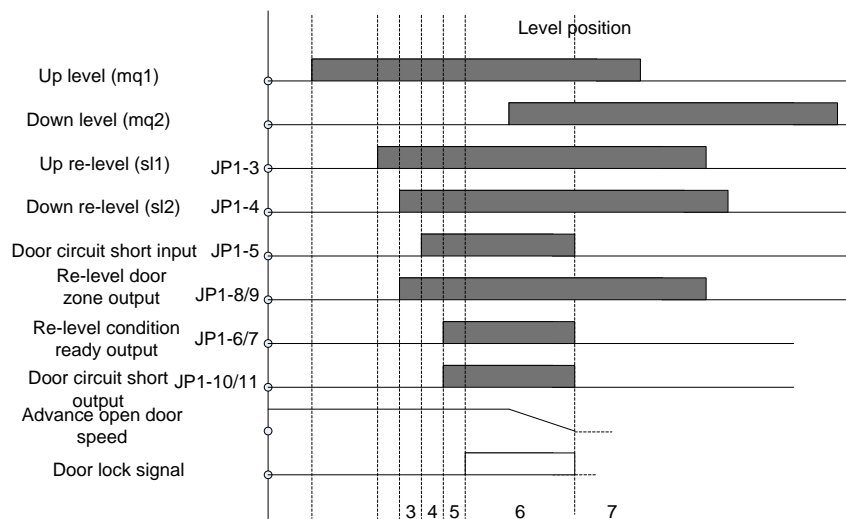

Figure 8 Advance open door time sequence while up running

1: Enter up level sensor; 2: Enter up re-leveling sensor; 3: Enter safety unlocking zone; 4: Control system find safety zone and speed is lower than set value, then output door circuit short control; 5: Door circuit short complete; 6: Control system find all condition satisfied; 6: Control system operate open door in low speed; 7: Stop complete and release door circuit short.

3.7.2 Re-leveling

When elevator stops at unlocking zone, car may deviate from level position because of rope telescopic change by car load vibration or some other reasons. Below the speed in International standard EN81-20/50 regulation, re-leveling board detect up and down re-leveling door zone signals and cooperate with elevator control board to short door circuit. Then start and run back to level zone in low speed with hall door and car door opened. The time sequence diagram is shown as follow:

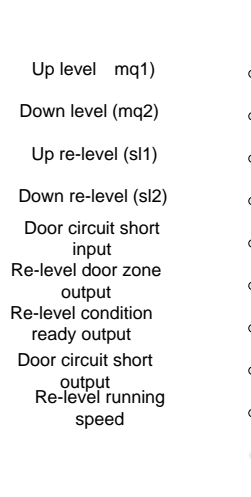

Figure 9 Re-leveling time sequence while up running

1: Control system find car deviate from level zone but still is in safety unlocking zone, then output door circuit short command; 2: Door circuit short complete, system start to run; 3: Elevator run back to level position in low speed; 4: Stop complete, release door circuit short.

3.7.3 Unintended Car movement detection with door opened

When elevator stop at level zone and hall door open with car door, this device parallel connect to door circuit and detect up & down re-leveling door zone signals. If car unintended move out of safety unlocking zone with car door or hall door opened, UCMP output will cut off and trigger brake subsystem to make car stop and hold it still. The time sequence is shown as follow:

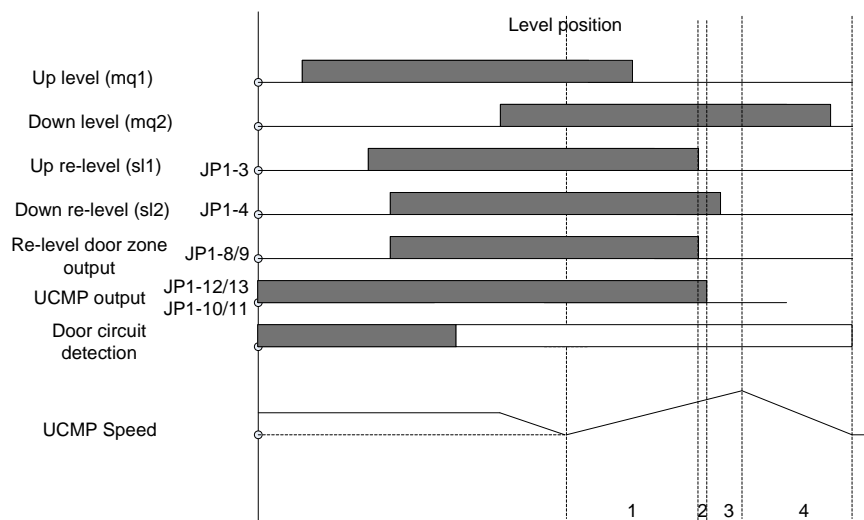



Figure 10 UCMP time sequence

4 Maintenance

4.1 Safety Precautions for Maintenance & Storage

| |
|--|
|  Danger |
| <p>The maintenance should only be done after cutting off power; There are high voltage terminals, please DO NOT TOUCH. Never reform safety monitor system voluntarily. Only authorized and qualified personnel are allowed to inspect/service integrated controller. DO NOT remove or change terminals and air wire when module power on. After maintenance, please make sure all terminals and contactors are tightly secured.</p> |
|  Caution |
| DO NOT touch control board directly, it use CMOS IC, please pay attention. |

4.2 Daily Check

Daily check normally including:

- 1 Check if the LED indicator is working properly.
- 2
- 3 Check if it is abnormal overheated.
- 4 Check if environment meet requirement of product.

4.3 Regular Check

Chart 3 Regular Check (Regular check period is 30 days for this system)

| Component | Terms for check | Judgment standard |
|-------------|--|---|
| Environment | <ol style="list-style-type: none"> 1. Check temperature and humidity of environment & vibration & dust & corrosive gas & oil & etc 2. re dangerous goods around. | <ol style="list-style-type: none"> 1. Suit for environment requirement of regulation 2. No dangerous goods. |
| Sensor | <ol style="list-style-type: none"> 1. Check if terminals are loose. 2. Check if sensor shell is damaged. | <ol style="list-style-type: none"> 1. No abnormal condition 2. No damage. |
| Wiring | Check if external protection shell is ageing or damaged. | No damage and ageing |

Chart 3 Regular Check (Regular check period is 30 days for this system) (Cont'd)

| Component | Terms for check | Judgment standard |
|-----------|-----------------|-------------------|
|-----------|-----------------|-------------------|